

Weight 1450 kg.

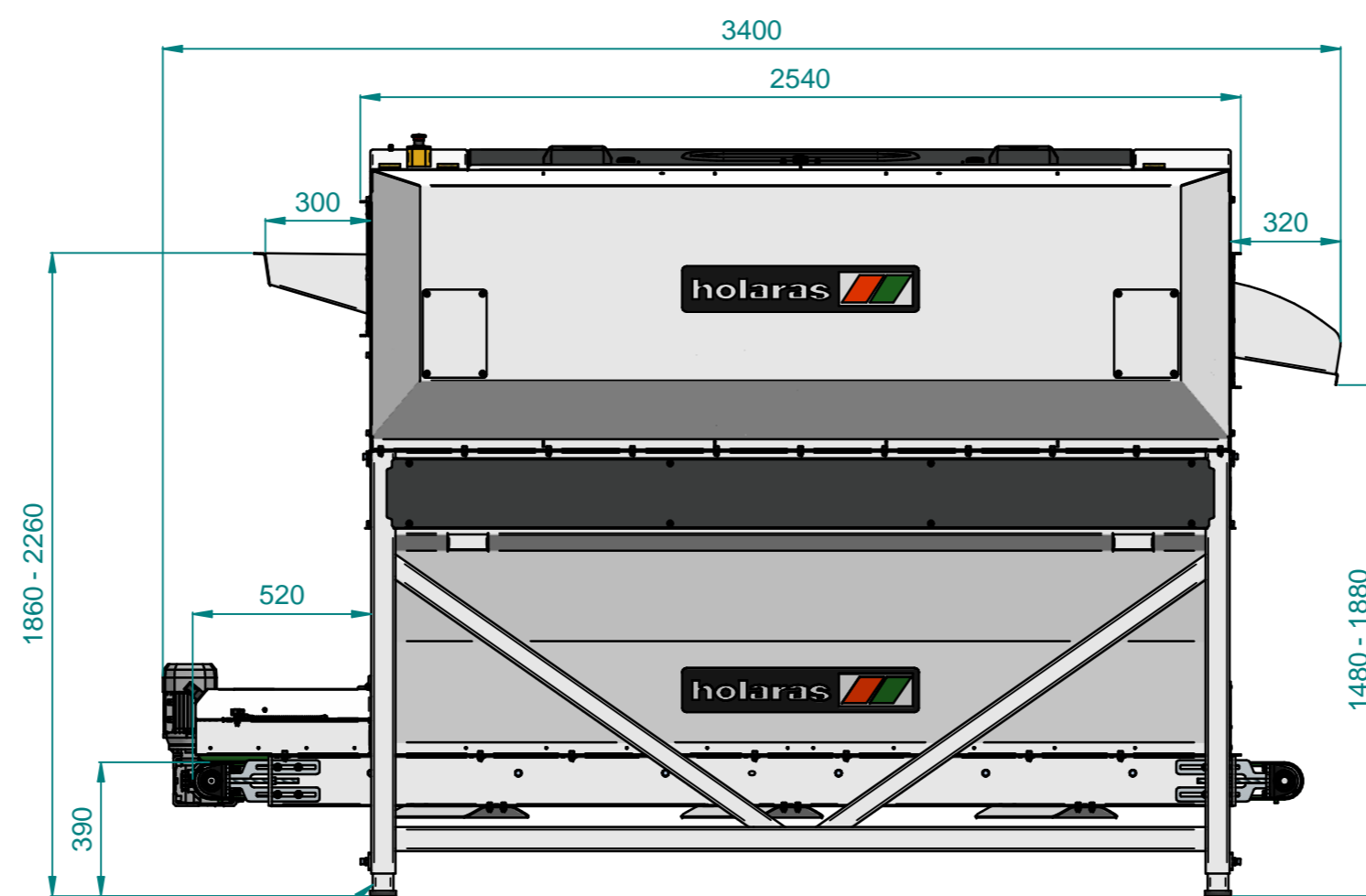

Legs can be extended with 350mm by turning a spindle in each leg.

Tilt the machine 1-2 degrees forward for an optimal flow and rotation of the onions.

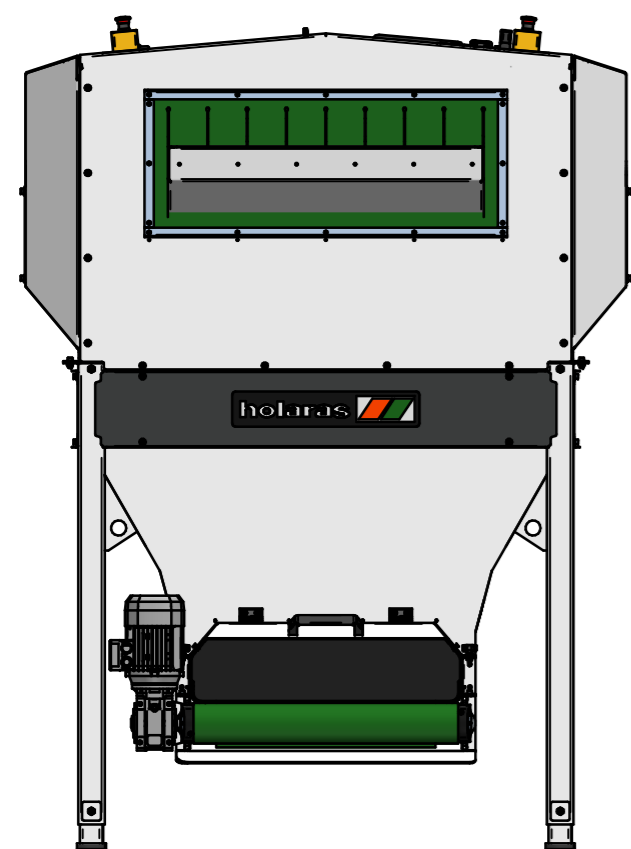
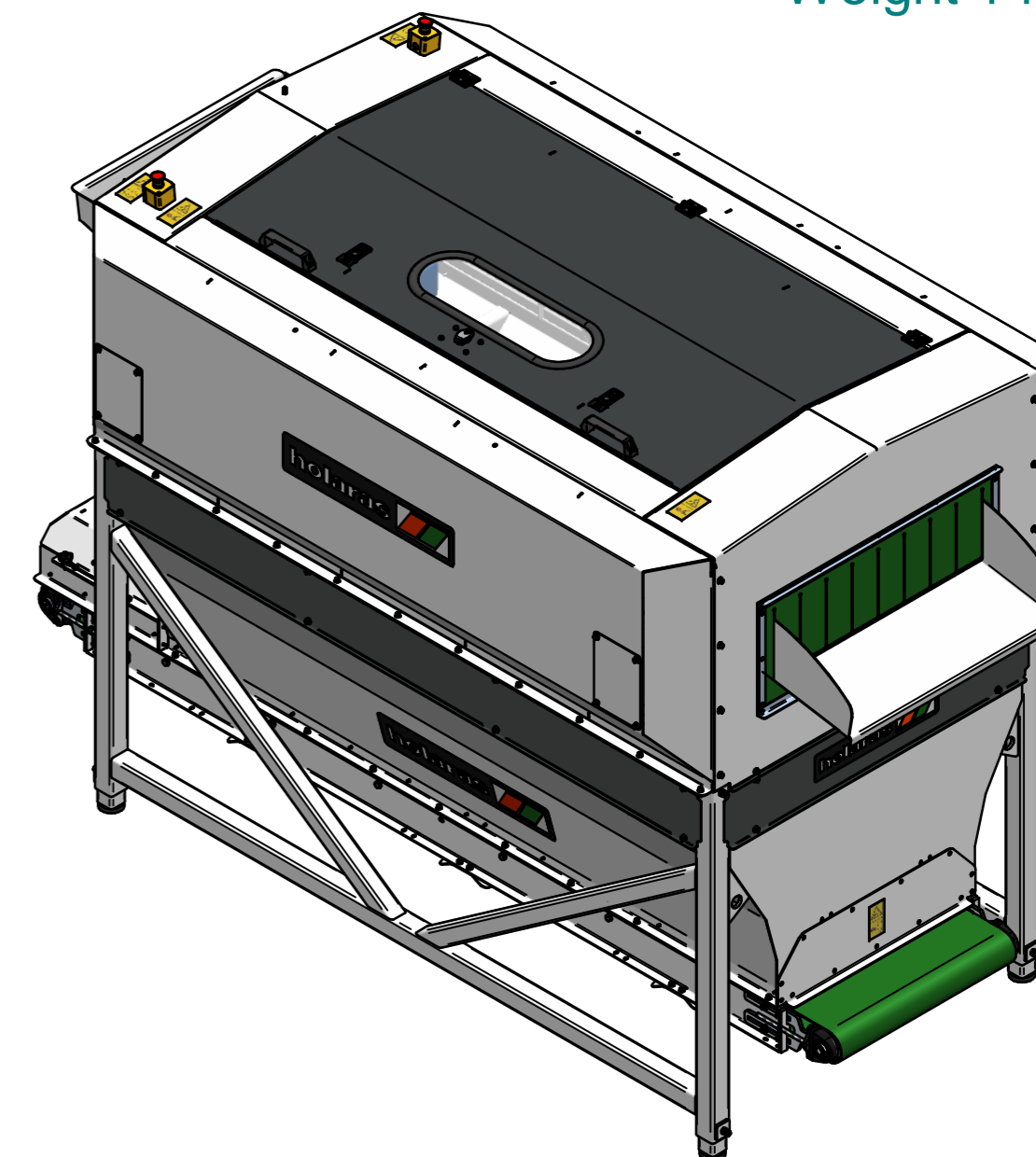
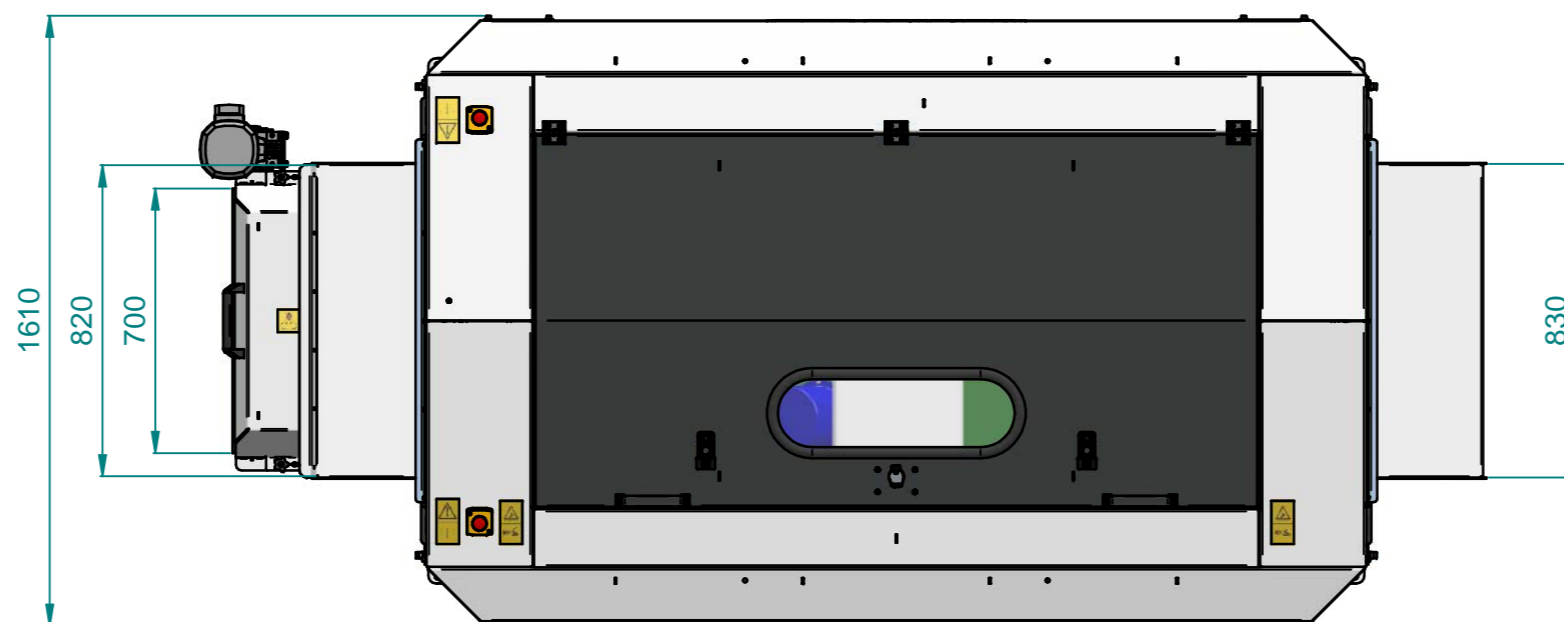
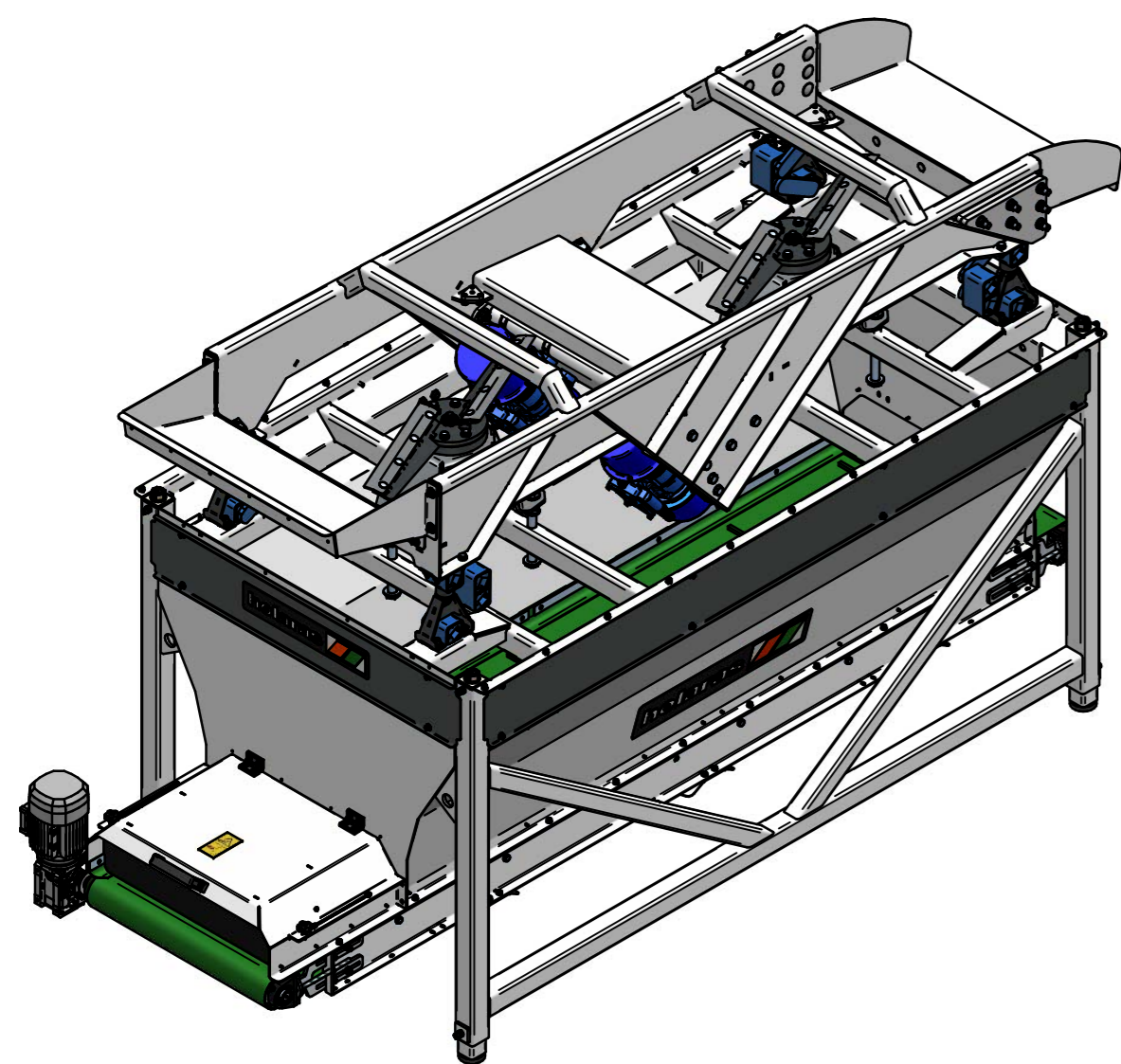
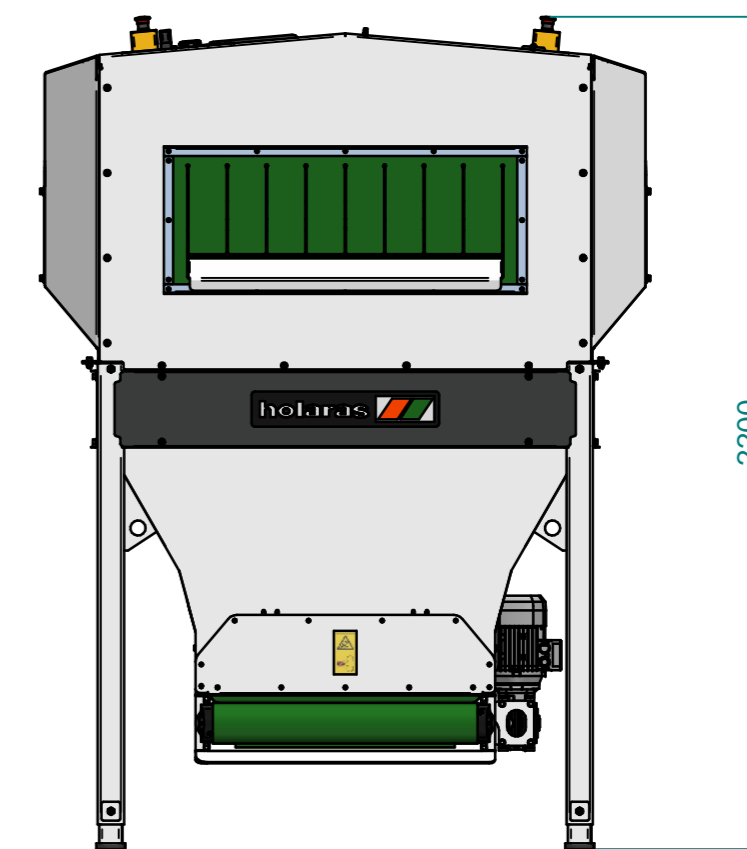

When top cover is opened, add approx. 1000mm to the total height.

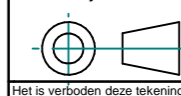
 Machinefabriek Holanda B.V. Dinxperlosestraatweg 145 NL - 7122 JP Aalten Tel.: +31(0)543-466224 Fax: +31(0)543-466464 @ : info@holaras.nl www.holaras.nl	Indien niet anders aangegeven Alg. tolerantie volgens ISO 2768-mK Therm. doorrijding volgens ISO 9013-2 Lasconstructies volgens ISO 13920-BE Hoeken zonder bemaaling zijn 90°		Benaming Onion topper AS10 Dimension sheet	
	Am. Proj. 	Schaal 1:20	Materiaal: B x H: 0x0 Diameter: ø0	Lengte: 0 Wanddikte: 0
Datum 29-3-2023	Afwerking:	Get. bhk	Contr. Tek. nr. 08A201	Pos. 00A
Art. nr.	Aantal	Rev. A2		